

- Tentative Specification
- Preliminary Specification
- Approval Specification

MODEL NO.: V236BJ1
SUFFIX: LE2

Customer:	
APPROVED BY	SIGNATURE
Name / Title _____	_____
Note	
Please return 1 copy for your confirmation with your signature and comments.	

Approved By	Checked By	Prepared By
Chao-Chun Chung	Ying-Ping Lee	Bowei Huang

CONTENTS

1. GENERAL DESCRIPTION	5
1.1 OVERVIEW	5
1.2 FEATURES.....	5
1.3 APPLICATION	5
1.4 GENERAL SPECIFICATIONS	5
1.5 MECHANICAL SPECIFICATIONS	6
2. ABSOLUTE MAXIMUM RATINGS	7
2.1 ABSOLUTE RATINGS OF ENVIRONMENT	7
2.2 PACKAGE STORAGE.....	8
2.3 ELECTRICAL ABSOLUTE RATINGS	8
2.3.1 TFT LCD MODULE	8
2.3.2 BACKLIGHT CONVERTER UNIT	8
3. ELECTRICAL CHARACTERISTICS.....	9
3.1 TFT LCD MODULE	9
3.2 BACKLIGHT CONNECTOR PIN CONFIGURATION.....	11
3.2.1 LED LIGHT BAR CHARACTERISTICS	11
3.2.2 LIGHTBAR CONNECTOR PIN ASSIGNMENT	12
3.3 LVDS INPUT SIGNAL SPECIFICATIONS.....	12
4. BLOCK DIAGRAM OF INTERFACE.....	13
4.1 TFT LCD MODULE	13
5. INPUT TERMINAL PIN ASSIGNMENT	14
5.1 TFT LCD MODULE INPUT	14
5.3 BLOCK DIAGRAM OF INTERFACE	16
5.4 LVDS INTERFACE	17
5.5 COLOR DATA INPUT ASSIGNMENT	18
6. INTERFACE TIMING.....	19
6.1 INPUT SIGNAL TIMING SPECIFICATIONS	19
6.2 POWER ON/OFF SEQUENCE	22
7. OPTICAL CHARACTERISTICS.....	23
7.1 TEST CONDITIONS.....	23
7.2 OPTICAL SPECIFICATIONS	24

8. PRECAUTIONS.....	28
8.1 ASSEMBLY AND HANDLING PRECAUTIONS	28
8.2 SAFETY PRECAUTIONS	28
9. DEFINITION OF LABELS.....	29
9.1 INX MODULE LABEL.....	29
10. PACKAGING.....	30
10.1 PACKING SPECIFICATIONS.....	30
10.2 PACKAGING METHOD.....	30
11. MECHANICAL CHARACTERISTIC	33

1. GENERAL DESCRIPTION

1.1 OVERVIEW

V236BJ1-LE2 is a 23.6" TFT Liquid Crystal Display module with WLED Backlight unit and 30 pins 1ch-LVDS interface. This module supports 1366 x 768 HDTV format and can display up to 16.7M (8 bit) colors. The converter module for Backlight is not built in.

1.2 FEATURES

- High brightness (250 nits)
- High contrast ratio (3000:1)
- Fast response time (Gray to gray average 8.5 ms)
- High color saturation (NTSC 72%)
- HDTV (1366 x 768 pixels) resolution, true HDTV format
- DE (Data Enable) only mode
- LVDS (Low Voltage Differential Signaling) interface
- Optimized response time for 60 Hz frame rate
- Ultra wide Viewing Angle: Super MVA Technology
- RoHS compliance.

1.3 APPLICATION

- Personal TV /Public Display Application
- Home Theater Application
- MFM Application

1.4 GENERAL SPECIFICATIONS

Item	Specification	Unit	Note
Active Area	521.4705 (H) x 293.184 (V)	mm	(1)
Bezel Opening Area	525.22 (H) x 297.22 (V)	mm	
Driver Element	a-si TFT active matrix	-	-
Pixel Number	1366 x R.G.B. x 768	pixel	-
Pixel Pitch(Sub Pixel)	0.12725 (H) x 0.38175 (V)	mm	-
Pixel Arrangement	RGB vertical stripe	-	-
Power consumption	22.849 (Max.) [Cell PW 6.349W (Max.) + BLU PW 16.50 (Max.)]	Watt	(2)
Display Colors	16.7M	color	-
Display Operation Mode	Transmissive Mode / Normally Black	-	-
Surface Treatment	Anti-Glare coating (Haze 1.0%),Hard coating (3H)	-	-

Note (1) Please refer to the attached drawings in chapter 11 for more information about the front and back outlines.

Note (2) Please refer sec 3.1 and 3.2 for more information of Power consumption.

1.5 MECHANICAL SPECIFICATIONS

Item		Min.	Typ.	Max.	Unit	Note
Module Size	Horizontal (H)	544.3	544.8	545.3	mm	(1)
	Vertical (V)	320.0	320.5	321.0	mm	(1)
	Depth (D)	10.9	11.4	11.9	mm	(1)
Weight		2010	2100	2190	g	-

Note (1) Please refer to the attached drawings for more information of front and back outline dimensions.

2. ABSOLUTE MAXIMUM RATINGS

2.1 ABSOLUTE RATINGS OF ENVIRONMENT

Item	Symbol	Value		Unit	Note
		Min.	Max.		
Storage Temperature	TST	-20	+60	°C	(1)
Operating Ambient Temperature	TOP	0	50	°C	(1), (2)
Shock (Non-Operating)	SNOP	-	50	G	(3), (5)
Vibration (Non-Operating)	VNOP	-	1.0	G	(4), (5)

Note (1) Temperature and relative humidity range is shown in the figure below.

- (a) 90 %RH Max. ($T_a \leq 40\text{ }^\circ\text{C}$).
- (b) Wet-bulb temperature should be 39 °C Max. ($T_a > 40\text{ }^\circ\text{C}$).
- (c) No condensation.

Note (2) The maximum operating temperature is based on the test condition that the surface temperature of display area is less than or equal to 65 °C with LCD module alone in a temperature controlled chamber. Thermal management should be considered in final product design to prevent the surface temperature of display area from being over 65 °C. The range of operating temperature may degrade in case of improper thermal management in final product design.

Note (3) 11 ms, half sine wave, 1 time for $\pm X$, $\pm Y$, $\pm Z$.

Note (4) 10 ~ 200 Hz, 30 min, 1 time each X, Y, Z.

Note (5) At testing Vibration and Shock, the fixture in holding the module has to be hard and rigid enough so that the module would not be twisted or bent by the fixture.

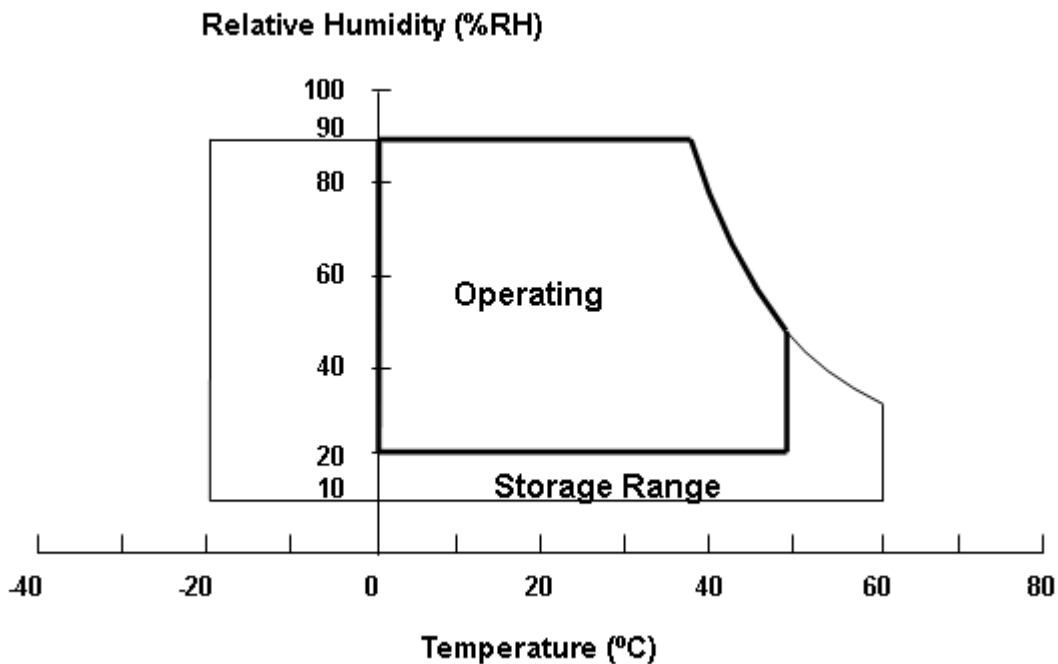

2.2 PACKAGE STORAGE

When storing modules as spares for a long time, the following precaution is necessary.

- (a) Do not leave the module in high temperature, and high humidity for a long time, It is highly recommended to store the module with temperature from 0 to 35 °C at normal humidity without condensation.
- (b) The module shall be stored in dark place. Do not store the TFT-LCD module in direct sunlight or fluorescent light.

2.3 ELECTRICAL ABSOLUTE RATINGS

2.3.1 TFT LCD MODULE

Item	Symbol	Value		Unit	Note
		Min.	Max.		
Power Supply Voltage	V _{CC}	-0.3	13.5	V	(1)
Logic Input Voltage	V _{IN}	-0.3	3.6	V	

2.3.2 BACKLIGHT CONVERTER UNIT

Item	Symbol	Value			Unit	Note
		Min.	Typ.	Max.		
LED Forward Current Per Input Pin	I _F	—	230	243.8	mA	(1) (2) Duty=100%
LED Pulse Forward Current Per Input Pin	I _{FP}	—	—	450	mA	Pulse Width ≤ 10msec. and Duty ≤ 25%

Note (1) Permanent damage to the device may occur if maximum values are exceeded. Function operation should be restricted to the conditions described under Normal Operating Conditions.

Note (2) Specified values are for input pin of LED light bar at Ta=25±2 °C (Refer to 3.2 for further information).

3. ELECTRICAL CHARACTERISTICS

3.1 TFT LCD MODULE

(Ta = 25 ± 2 °C)

Parameter	Symbol	Value			Unit	Note	
		Min.	Typ.	Max.			
Power Supply Voltage	V _{CC}	10.8	12	13.2	V	(1)	
Rush Current	I _{RUSH}	—	—	3.9	A	(2)	
Power consumption	P _T	—	4.88	6.349	Watt	(3)	
Power Supply Current	White Pattern	—	0.35	0.455	A	(4)	
	Horizontal Stripe	—	0.37	0.481	A		
	Black Pattern	—	0.21	0.273	A		
LVDS interface	Differential Input High Threshold Voltage	V _{LVTH}	+100	—	—	mV	(5)
	Differential Input Low Threshold Voltage	V _{LVTL}	—	—	-100	mV	
	Common Input Voltage	V _{CM}	1.0	1.2	1.4	V	
	Differential input voltage (single-end)	V _{ID}	200	—	600	mV	
	Terminating Resistor	R _T	—	100	—	ohm	
CMIS interface	Input High Threshold Voltage	V _{IH}	2.7	—	3.3	V	-
	Input Low Threshold Voltage	V _{IL}	0	—	0.7	V	-

Note (1) The module should be always operated within the above ranges.

Note (2) Measurement condition:

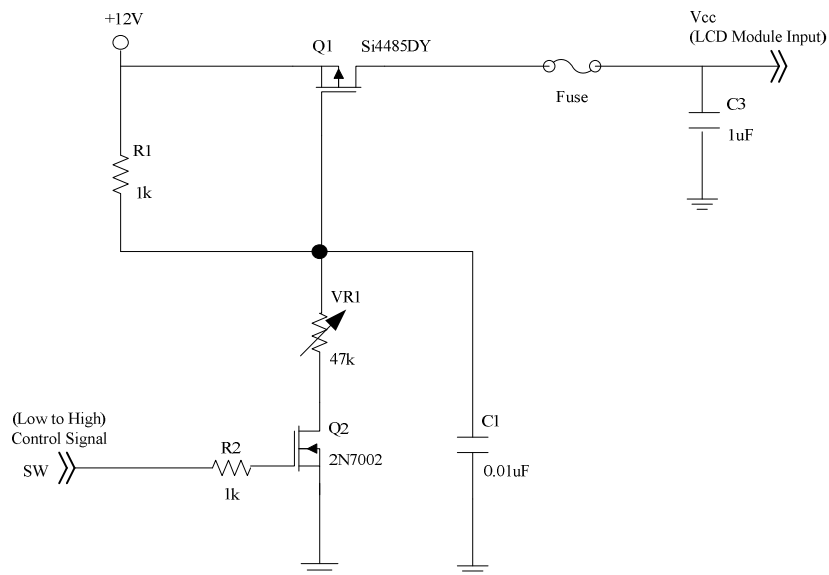

Vcc rising time is 470us

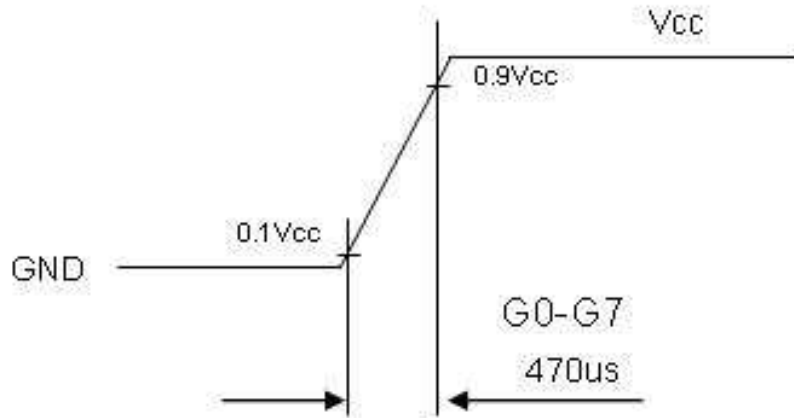

Note (3) The Specified Power consumption is under White pattern.

Note (4) The specified power supply current is under the conditions at $V_{cc} = 12\text{ V}$, $T_a = 25 \pm 2\text{ }^\circ\text{C}$, $f_v = 60\text{ Hz}$, whereas a power dissipation check pattern below is displayed.

a. White Pattern

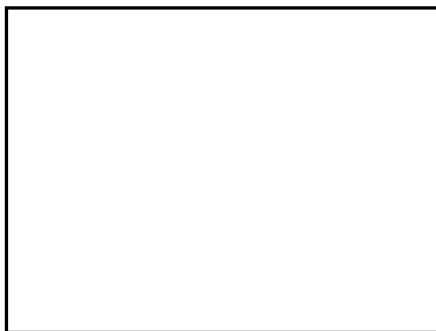

Active Area

b. Black Pattern



Active Area

c. Horizontal Pattern

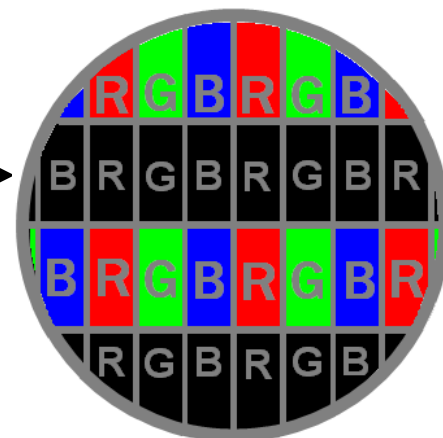
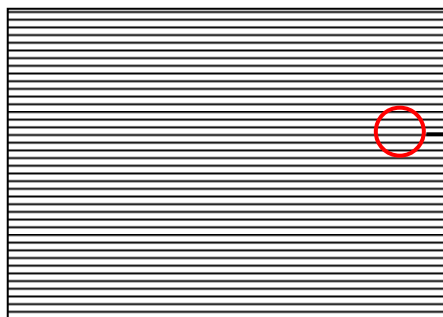

Note (5) The LVDS input characteristics are as follows :

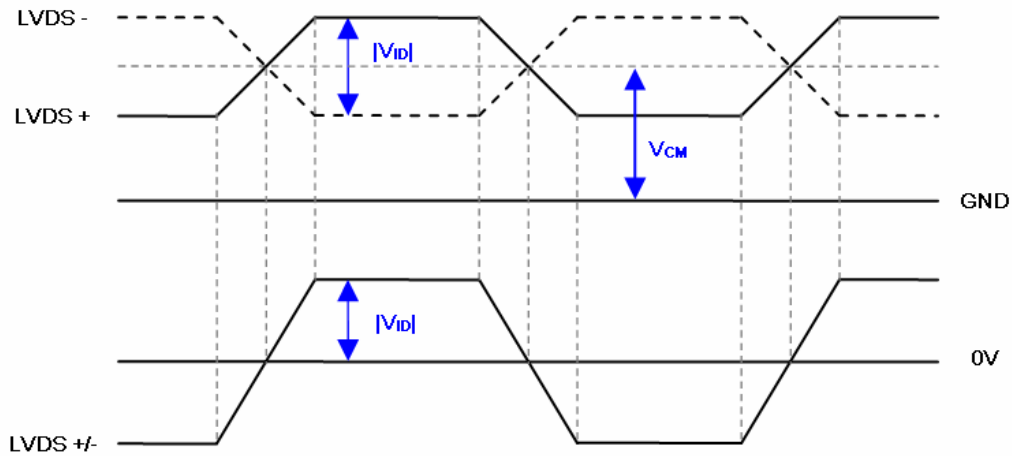

3.2 BACKLIGHT CONNECTOR PIN CONFIGURATION

3.2.1 LED LIGHT BAR CHARACTERISTICS

(Ta = 25 ± 2 °C)

Parameter	Symbol	Value			Unit	Note
		Min.	Typ.	Max.		
LED Light Bar Input Voltage Per Input Pin	V _{PIN}	---	31.23	35.55	v	(1), Duty=100%, I _L =230mA
LED Light Bar Current Per Input Pin	I _{PIN}	---	230	243.8	mA	(1), (2) Duty=100%
Power consumption	P _{BL}	---	14.5	16.5	W	(1), (2) Duty=100%, I _L =230mA
LED Life time	L _{LED}	30,000	—	—	Hrs	(3)

Note (1) LED light bar input voltage and current are measured by utilizing a true RMS multimeter as shown below:

Note (2) P_{BL}(Typ.)= I_{PIN}(Typ.) × V_{PIN}(Typ.) × (2), P_{BL}(Max.)= I_{PIN}(Typ) × V_{PIN}(Max.) × (2) input pins ,

Note (3) The lifetime of LED is defined as the time when LED packages continue to operate under the conditions at Ta = 25 ± 2 °C and (I= 230mA) (per chip) until the brightness becomes ≤ 50% of its original value.

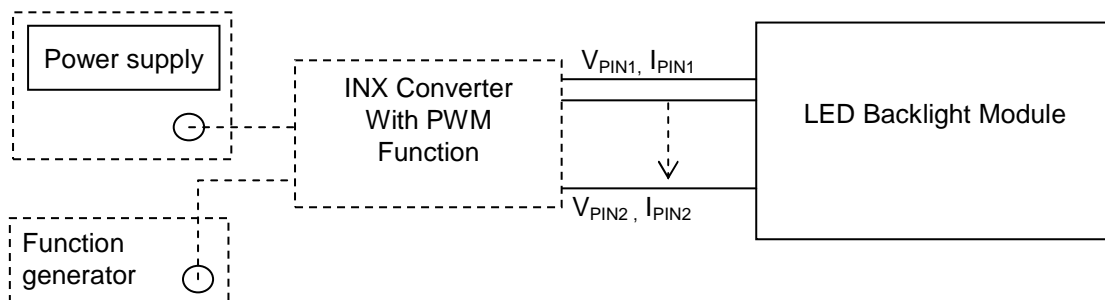

3.2.2 LIGHTBAR CONNECTOR PIN ASSIGNMENT

Connector: WM13-406-063N (FCN)

CI1406M1HRK-NH (CviLux)

Input connector pin assignment: CN1

Input connector CN1		Comments
(vendor)	(type)	
FCN	WM13-406-063N	
CviLux	CI1406M1HRK-NH	
Pin	Function	
1	VLED (31.23V)	VLED
2	NC	Not connection, this pin should be open
3	NC	Not connection, this pin should be open
4	NC	Not connection, this pin should be open
5	LED2	Cathode of LED string
6	LED1	Cathode of LED string

3.3 LVDS INPUT SIGNAL SPECIFICATIONS

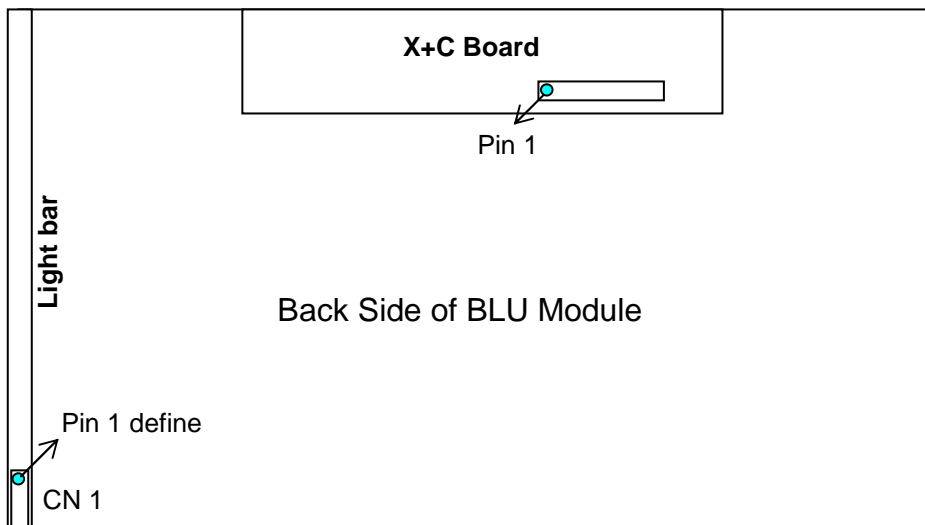

4. BLOCK DIAGRAM OF INTERFACE

4.1 TFT LCD MODULE

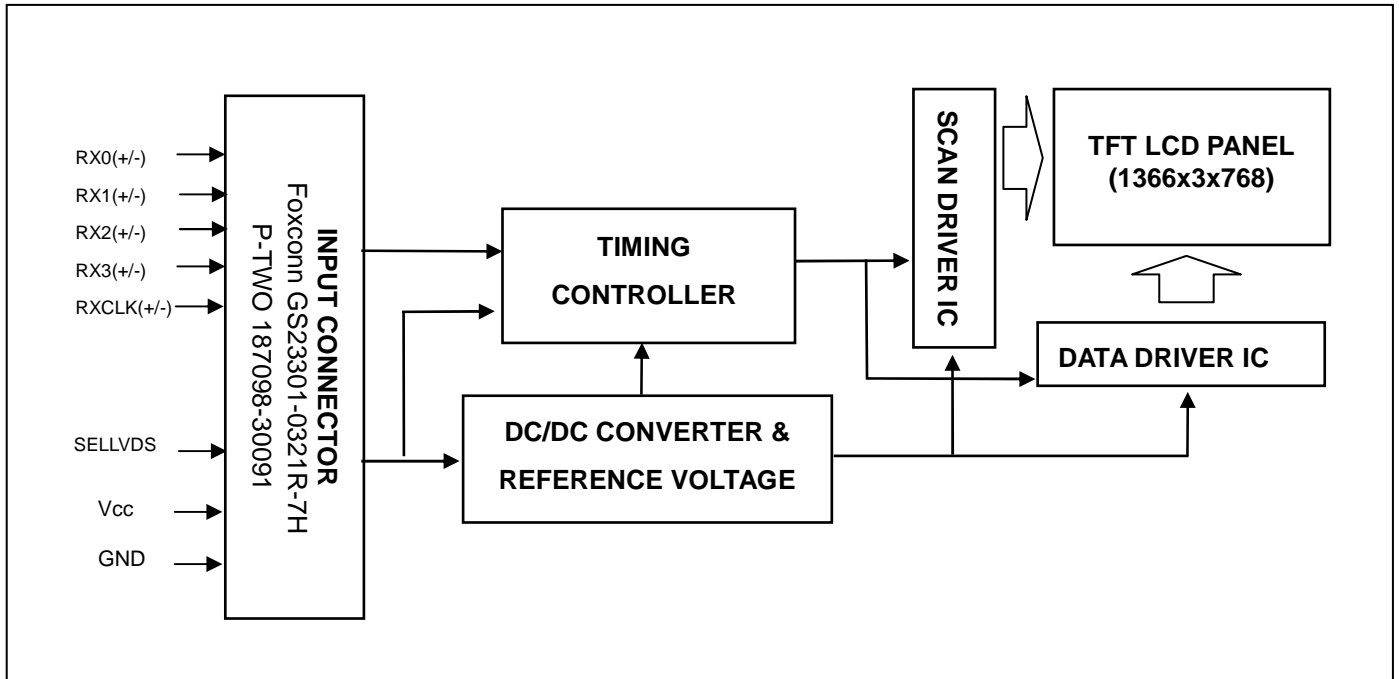

5. INPUT TERMINAL PIN ASSIGNMENT

5.1 TFT LCD MODULE INPUT

Connector Pin Assignment

Pin	Name	Description	Remark
1	VCC	+12.0V power supply	-
2	VCC	+12.0V power supply	-
3	VCC	+12.0V power supply	-
4	VCC	+12.0V power supply	-
5	GND	Ground	-
6	GND	Ground	-
7	GND	Ground	-
8	NC	No connection	(2)
9	SELLVDS	Select LVDS Format	(3)(4)
10	NC	NC	(2)
11	GND	Ground	-
12	RX0-	Negative LVDS differential data input. Channel 0	-
13	RX0+	Positive LVDS differential data input. Channel 0	-
14	GND	Ground	-
15	RX1-	Negative LVDS differential data input. Channel 1	-
16	RX1+	Positive LVDS differential data input. Channel 1	-
17	GND	Ground	-
18	RX2-	Negative LVDS differential data input. Channel 2	-
19	RX2+	Positive LVDS differential data input. Channel 2	-
20	GND	Ground	-
21	RXLCK-	Negative LVDS differential clock input.	-
22	RXCLK+	Positive LVDS differential clock input.	-
23	GND	Ground	-
24	RX3-	Negative LVDS differential data input. Channel 3	-
25	RX3+	Positive LVDS differential data input. Channel 3	-
26	GND	Ground	-
27	NC	No connection	(2)
28	NC	No connection	(2)
29	NC	No connection	(2)
30	GND	Ground	-

Note (1) Connector type: (FOXCONN= GS23301-0321R-7H or P-TWO=187098-30091)
LVDS connector pin order defined as follows

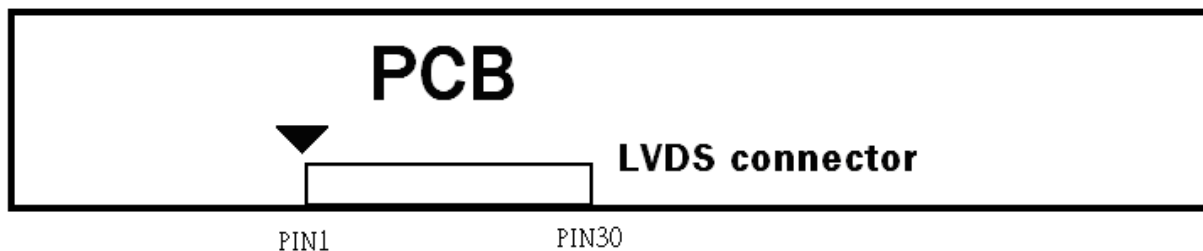

Note (2) Reserved for internal use. Please leave it open.

Note (3) LVDS data format Selection(0V~0.7V:VESA 2.7V~3.3V:OPEN→JEDIA)

Note (4) LVDS signal pin connected to the LCM side has the following diagram. R1 in the system side should be less than 1K Ohm. ($R1 < 1K \text{ Ohm}$)

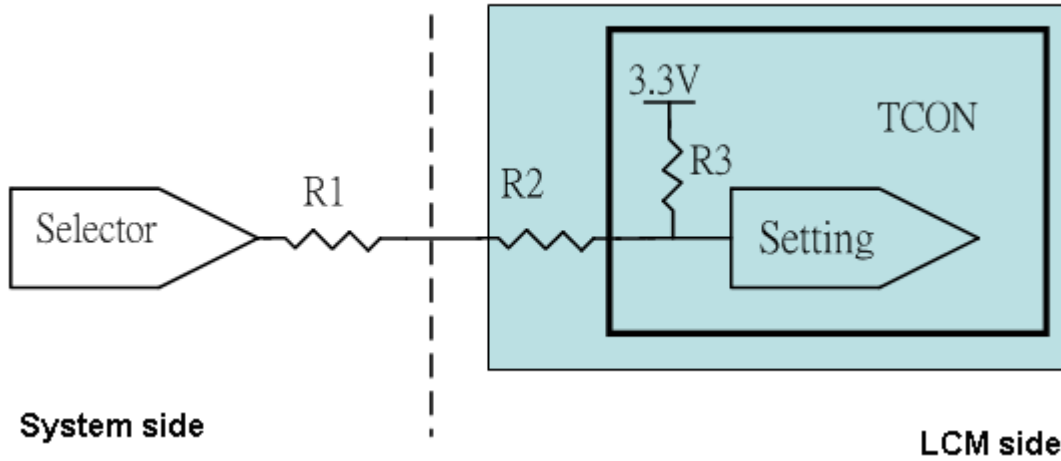

Note (5) Suggested connector connected in series : JAE FI-X30HL (Japan Aviation Electronics Ind., LTD.)

5.3 BLOCK DIAGRAM OF INTERFACE

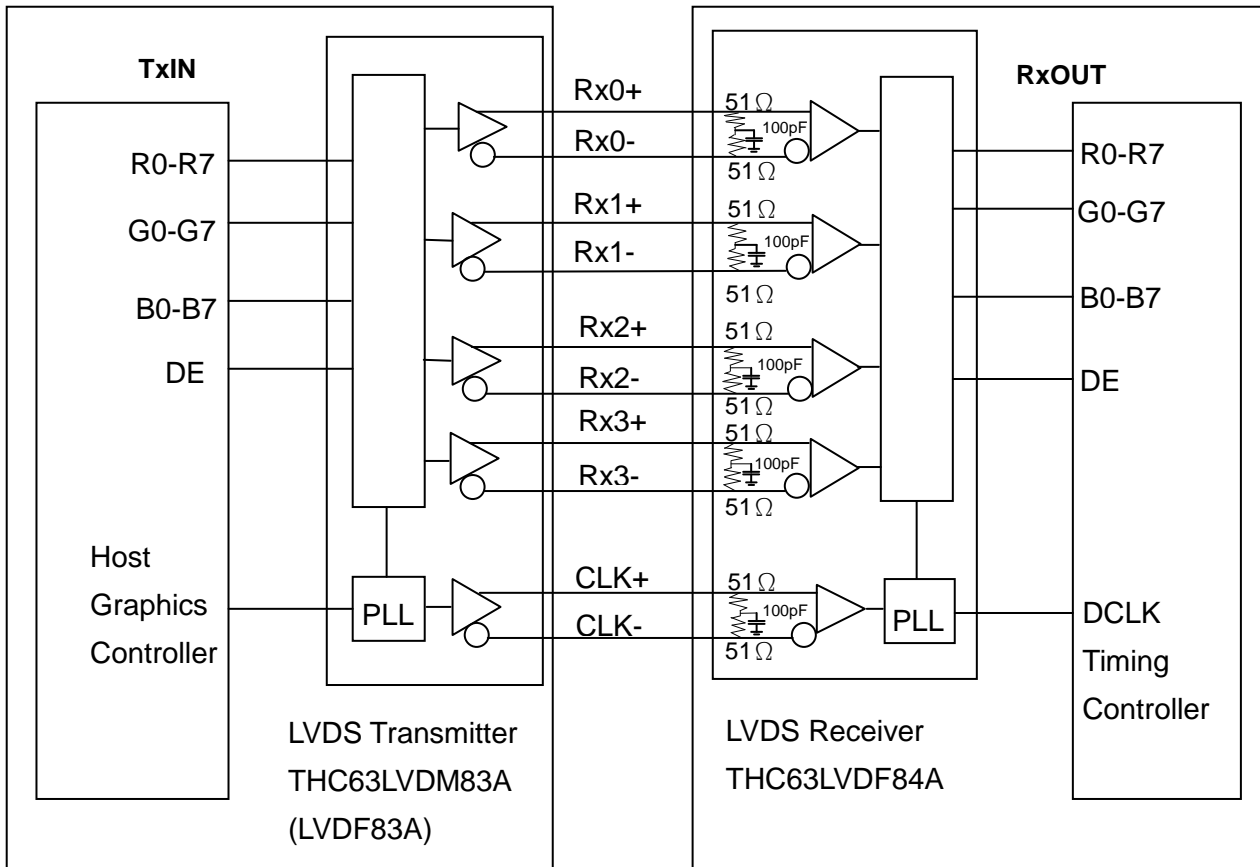

- R0~R7 : Pixel R Data ,
- G0~G7 : Pixel G Data ,
- B0~B7 : Pixel B Data ,
- DE : Data enable signal
- DCLK : Data clock signal

Note (1) The system must have the transmitter to drive the module.

Note (2) LVDS cable impedance shall be 50 ohms per signal line or about 100 ohms per twist-pair line when it is used differentially.

5.4 LVDS INTERFACE

VESA LVDS format : (SELLVDS pin= L)

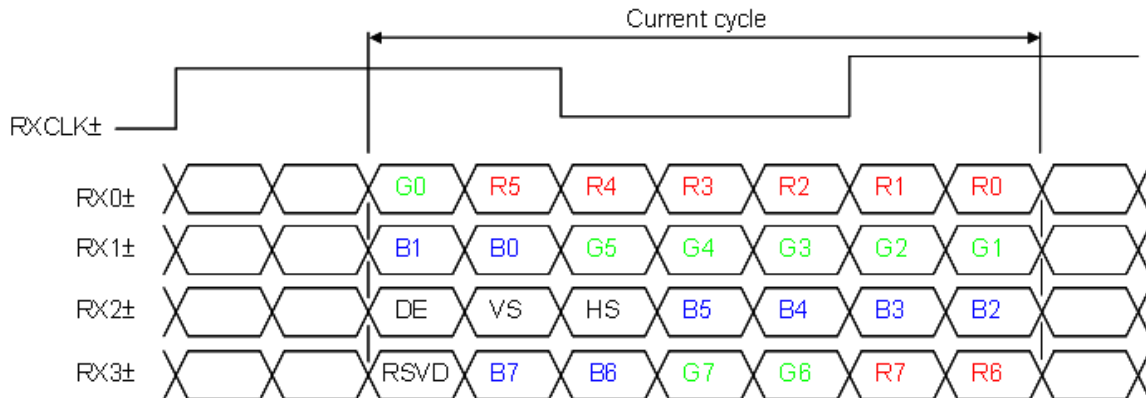

JEDIA LVDS format : (SELLVDS pin= H or Open)

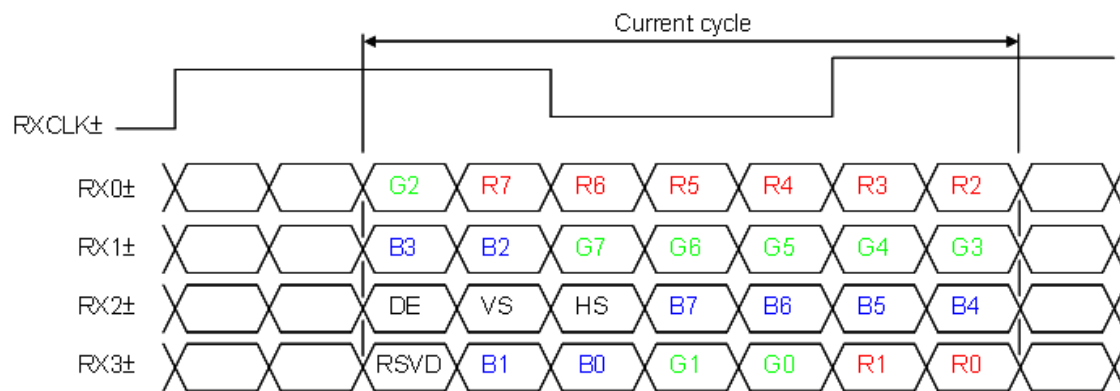

R0~R7: Pixel R Data (7; MSB, 0; LSB)

G0~G7: Pixel G Data (7; MSB, 0; LSB)

B0~B7: Pixel B Data (7; MSB, 0; LSB)

DE : Data enable signal

DCLK : Data clock signal

Notes: (1) RSVD (reserved) pins on the transmitter shall be "H" or "L".

5.5 COLOR DATA INPUT ASSIGNMENT

The brightness of each primary color (red, green and blue) is based on the 8-bit gray scale data input for the color. The higher the binary input, the brighter the color. The table below provides the assignment of the color versus data input.

Color		Data Signal																							
		Red								Green								Blue							
		R7	R6	R5	R4	R3	R2	R1	R0	G7	G6	G5	G4	G3	G2	G1	G0	B7	B6	B5	B4	B3	B2	B1	B0
Basic Colors	Black	0	0	0	0	0	0	0	0	0	0	0	0	0	0	0	0	0	0	0	0	0	0	0	0
	Red	1	1	1	1	1	1	1	1	0	0	0	0	0	0	0	0	0	0	0	0	0	0	0	0
	Green	0	0	0	0	0	0	0	0	1	1	1	1	1	1	1	1	0	0	0	0	0	0	0	0
	Blue	0	0	0	0	0	0	0	0	0	0	0	0	0	0	0	0	1	1	1	1	1	1	1	1
	Cyan	0	0	0	0	0	0	0	0	1	1	1	1	1	1	1	1	1	1	1	1	1	1	1	1
	Magenta	1	1	1	1	1	1	1	1	0	0	0	0	0	0	0	0	1	1	1	1	1	1	1	1
	Yellow	1	1	1	1	1	1	1	1	1	1	1	1	1	1	1	1	0	0	0	0	0	0	0	0
	White	1	1	1	1	1	1	1	1	1	1	1	1	1	1	1	1	1	1	1	1	1	1	1	1
Gray Scale Of Red	Red (0) / Dark	0	0	0	0	0	0	0	0	0	0	0	0	0	0	0	0	0	0	0	0	0	0	0	0
	Red (1)	0	0	0	0	0	0	0	1	0	0	0	0	0	0	0	0	0	0	0	0	0	0	0	0
	Red (2)	0	0	0	0	0	0	1	0	0	0	0	0	0	0	0	0	0	0	0	0	0	0	0	0
	:	:	:	:	:	:	:	:	:	:	:	:	:	:	:	:	:	:	:	:	:	:	:	:	:
	:	:	:	:	:	:	:	:	:	:	:	:	:	:	:	:	:	:	:	:	:	:	:	:	:
	:	:	:	:	:	:	:	:	:	:	:	:	:	:	:	:	:	:	:	:	:	:	:	:	:
	Red (253)	1	1	1	1	1	1	0	1	0	0	0	0	0	0	0	0	0	0	0	0	0	0	0	0
	Red (254)	1	1	1	1	1	1	1	0	0	0	0	0	0	0	0	0	0	0	0	0	0	0	0	0
Red (255)	1	1	1	1	1	1	1	1	0	0	0	0	0	0	0	0	0	0	0	0	0	0	0	0	
Gray Scale Of Green	Green (0) / Dark	0	0	0	0	0	0	0	0	0	0	0	0	0	0	0	0	0	0	0	0	0	0	0	0
	Green (1)	0	0	0	0	0	0	0	0	0	0	0	0	0	0	0	1	0	0	0	0	0	0	0	0
	Green (2)	0	0	0	0	0	0	0	0	0	0	0	0	0	0	1	0	0	0	0	0	0	0	0	0
	:	:	:	:	:	:	:	:	:	:	:	:	:	:	:	:	:	:	:	:	:	:	:	:	:
	:	:	:	:	:	:	:	:	:	:	:	:	:	:	:	:	:	:	:	:	:	:	:	:	:
	:	:	:	:	:	:	:	:	:	:	:	:	:	:	:	:	:	:	:	:	:	:	:	:	:
	Green (253)	0	0	0	0	0	0	0	0	1	1	1	1	1	1	0	1	0	0	0	0	0	0	0	0
	Green (254)	0	0	0	0	0	0	0	0	1	1	1	1	1	1	1	0	0	0	0	0	0	0	0	0
Green (255)	0	0	0	0	0	0	0	0	1	1	1	1	1	1	1	1	0	0	0	0	0	0	0	0	
Gray Scale Of Blue	Blue (0) / Dark	0	0	0	0	0	0	0	0	0	0	0	0	0	0	0	0	0	0	0	0	0	0	0	0
	Blue (1)	0	0	0	0	0	0	0	0	0	0	0	0	0	0	0	0	0	0	0	0	0	0	0	1
	Blue (2)	0	0	0	0	0	0	0	0	0	0	0	0	0	0	0	0	0	0	0	0	0	0	1	0
	:	:	:	:	:	:	:	:	:	:	:	:	:	:	:	:	:	:	:	:	:	:	:	:	:
	:	:	:	:	:	:	:	:	:	:	:	:	:	:	:	:	:	:	:	:	:	:	:	:	:
	:	:	:	:	:	:	:	:	:	:	:	:	:	:	:	:	:	:	:	:	:	:	:	:	:
	Blue (253)	0	0	0	0	0	0	0	0	0	0	0	0	0	0	0	0	1	1	1	1	1	1	0	1
	Blue (254)	0	0	0	0	0	0	0	0	0	0	0	0	0	0	0	0	1	1	1	1	1	1	1	0
Blue (255)	0	0	0	0	0	0	0	0	0	0	0	0	0	0	0	0	1	1	1	1	1	1	1	1	

Note (1) 0: Low Level Voltage, 1: High Level Voltage

6. INTERFACE TIMING

6.1 INPUT SIGNAL TIMING SPECIFICATIONS

The input signal timing specifications are shown as the following table and timing diagram. ($T_a = 25 \pm 2 \text{ }^\circ\text{C}$)

Signal	Item	Symbol	Min.	Typ.	Max.	Unit	Note
LVDS Receiver Clock	Frequency	$F_{\text{clkin}} (=1/TC)$	67.7	76	82	MHz	-
	Input cycle to cycle jitter	T_{rcj}	—	—	200	ps	(2)
	Spread spectrum modulation range	$F_{\text{clkin_mod}}$	$F_{\text{clkin}}-2\%$	—	$F_{\text{clkin}}+2\%$	MHz	(3)
	Spread spectrum modulation frequency	F_{SSM}	—	—	200	KHz	
LVDS Receiver Data	Setup Time	T_{lvsu}	600	—	—	ps	-
	Hold Time	T_{lvhd}	600	—	—	ps	
Vertical Active Display Term	Frame Rate	F_{r5}	47	50	53	Hz	-
		F_{r6}	57	60	63	Hz	
	Total	T_{v}	776	806	1050	Th	$T_{\text{v}}=T_{\text{vd}}+T_{\text{vb}}$
	Display	T_{vd}	768	768	768	Th	-
	Blank	T_{vb}	8	38	282	Th	-
Horizontal Active Display Term	Total	T_{h}	1530	1560	2006	Tc	$T_{\text{h}}=T_{\text{hd}}+T_{\text{hb}}$
	Display	T_{hd}	1366	1366	1366	Tc	-
	Blank	T_{hb}	164	194	640	Tc	-

Note (1) Please make sure the range of frame rate has follow the below equation :

$$F_{\text{clkin}}(\text{max}) \geq F_{\text{r6}} \times T_{\text{v}} \times T_{\text{h}}$$

$$F_{\text{r5}} \times T_{\text{v}} \times T_{\text{h}} \geq F_{\text{clkin}}(\text{min})$$

Note (2) This module is operated in DE only mode and please follow the input signal timing diagram below :

INPUT SIGNAL TIMING DIAGRAM

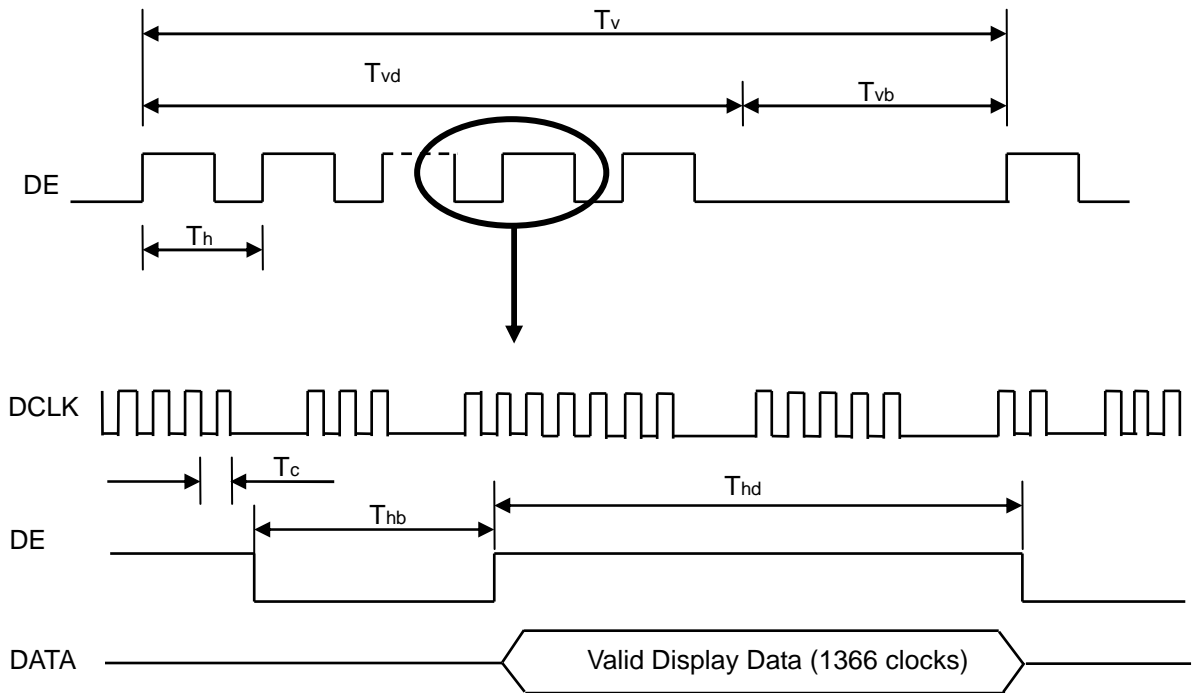

Note (3) The input clock cycle-to-cycle jitter is defined as below figures. $Trcl = |T_1 - T_2|$

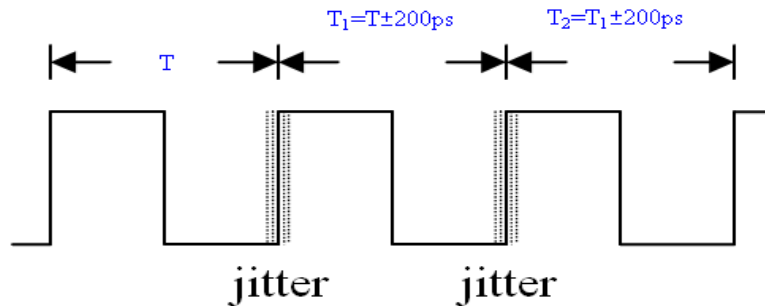

Note (4) The SSCG (Spread spectrum clock generator) is defined as below figures.

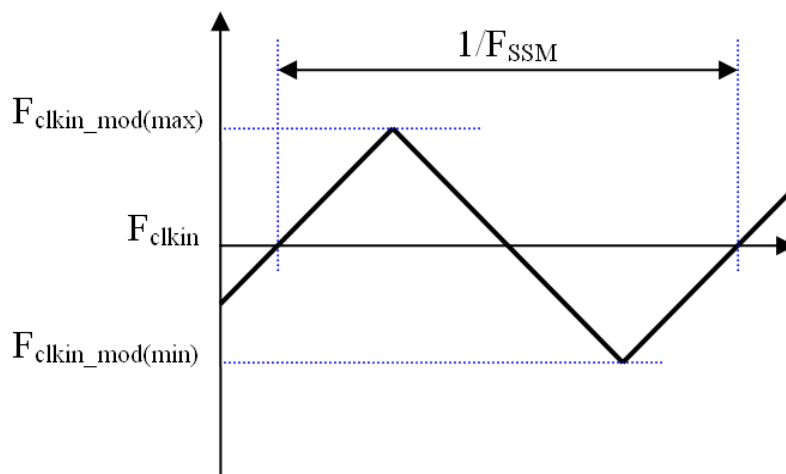

Note (5) The LVDS timing diagram and setup/hold time is defined and showing as the following figures.

LVDS RECEIVER INTERFACE TIMING DIAGRAM

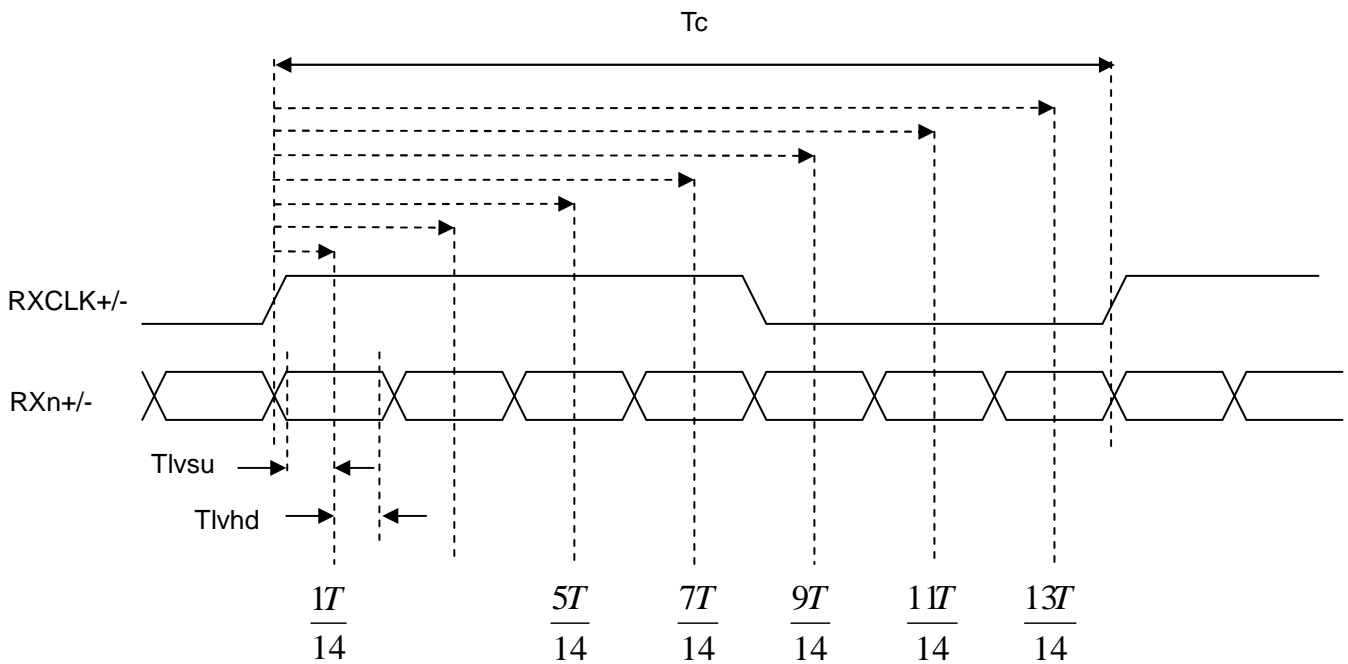

6.2 POWER ON/OFF SEQUENCE

(Ta = 25 ± 2 °C)

To prevent a latch-up or DC operation of LCD module, the power on/off sequence should be as the diagram below.

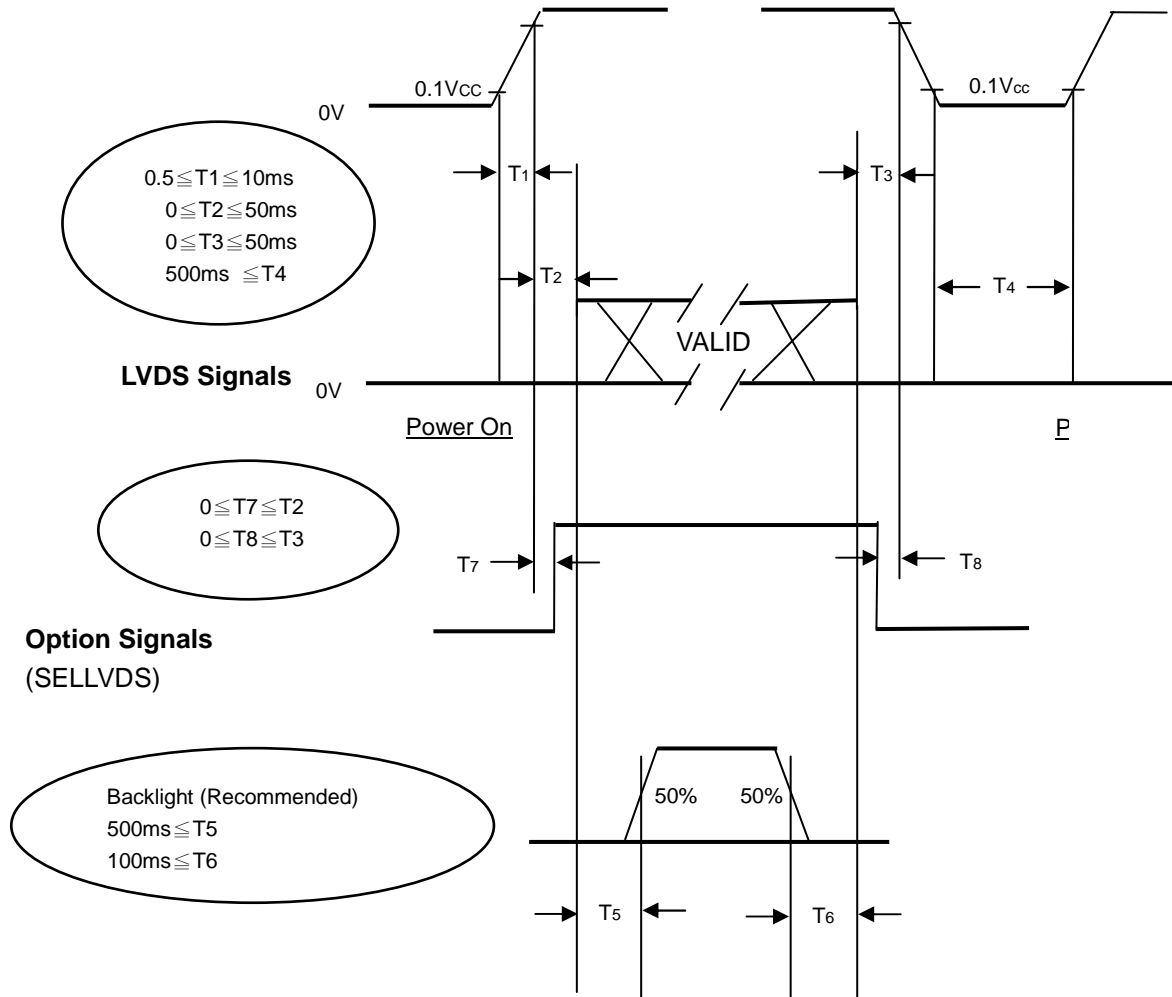

Power ON/OFF Sequence

Note (1) The supply voltage of the external system for the module input should follow the definition of Vcc.

Note (2) Apply the lamp voltage within the LCD operation range. When the backlight turns on before the LCD operation or the LCD turns off before the backlight turns off, the display may momentarily become abnormal screen.

Note (3) In case of Vcc is in off level, please keep the level of input signals on the low or high impedance.

Note (4) T4 should be measured after the module has been fully discharged between power off and on period.

Note (5) Interface signal shall not be kept at high impedance when the power is on.

7. OPTICAL CHARACTERISTICS

7.1 TEST CONDITIONS

Item	Symbol	Value	Unit
Ambient Temperature	Ta	25±2	°C
Ambient Humidity	Ha	50±10	%RH
Supply Voltage	VCC	12	V
Input Signal	According to typical value in "3. ELECTRICAL CHARACTERISTICS"		
LED Light Bar Input Current Per Input Pin	I _{PIN}	230	mA _{DC}
PWM Duty Ratio	D	100	%

The LCD module should be stabilized at given temperature for 1 hour to avoid abrupt temperature change during measuring. In order to stabilize the luminance, the measurement should be executed after lighting backlight for 1 hour in a windless room.

7.2 OPTICAL SPECIFICATIONS

The relative measurement methods of optical characteristics are shown in 7.2. The following items should be measured under the test conditions described in 7.1 and stable environment shown in 7.1.

Item		Symbol	Condition	Min.	Typ.	Max.	Unit	Note
Contrast Ratio		CR		2000	3000	-	-	(2)
Response Time		Gray to gray		-	8.5	20	ms	(3)
Center Luminance of White		L_c		200	250	-	cd/m ²	(5)
White Variation		δW		-	-	1.42		(7)
Cross Talk		CT		-	-	4.0	%	(6)
Color Chromaticity	Red	Rx		$\theta_x=0^\circ, \theta_y=0^\circ$ Viewing angle at normal direction	Typ. -0.03	0.643	Typ. +0.03	-
		Ry	0.339			-		
	Green	Gx	0.316			-		
		Gy	0.613			-		
	Blue	Bx	0.152			-		
		By	0.054			-		
	White	Wx	0.285			-		
		Wy	0.293			-		
	Color Gamut		C.G			-		72
Viewing Angle	Horizontal	θ_{x+}	CR \geq 10 With INX Module	80	89	-	Deg.	(1)(4)
		θ_{x-}		80	89	-		
	Vertical	θ_{Y+}		80	89	-		
		θ_{Y-}		80	89	-		

Note (1) Definition of Viewing Angle (θ_x, θ_y) :

Viewing angles are measured by Autronic Conoscope Cono-80

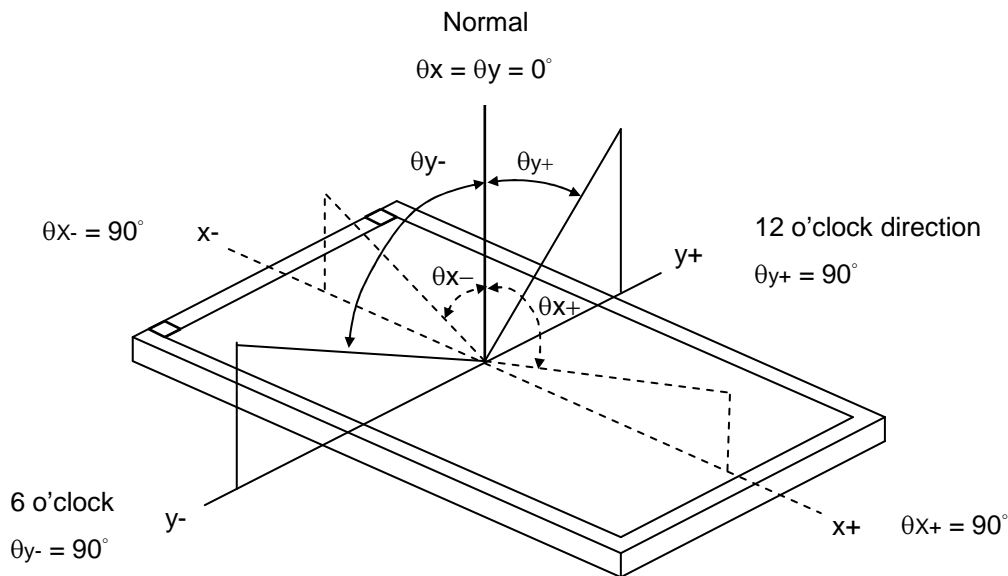

Note (2) Definition of Contrast Ratio (CR) :

The contrast ratio can be calculated by the following expression.

$$\text{Contrast Ratio (CR)} = \frac{\text{Surface Luminance with all white pixels}}{\text{Surface Luminance with all black pixels}}$$

CR = CR (5), where CR (X) is corresponding to the Contrast Ratio of the point X at the figure in Note(7).

Note (3) Definition of Gray-to-Gray Switching Time:

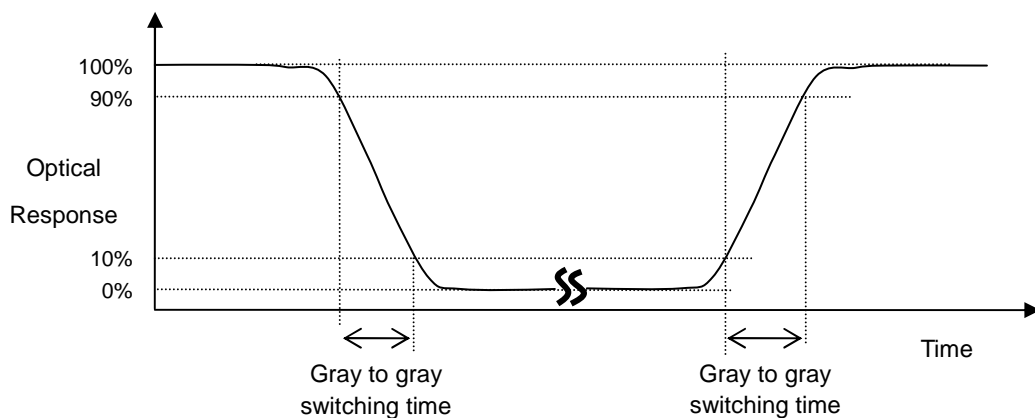

The driving signal means the signal of gray level 0, 31, 63, 95, 127, 159, 191, 223 and 255..

Gray to gray average time means the average switching time of gray level 0, 31, 63, 95, 127, 159, 191, 223 and 255 to each other.

Note (4) Measurement Setup:

The LCD module should be stabilized at given temperature for 1 hour to avoid abrupt temperature change during measuring. In order to stabilize the luminance, the measurement should be executed after lighting backlight for 1 hour in a windless room.

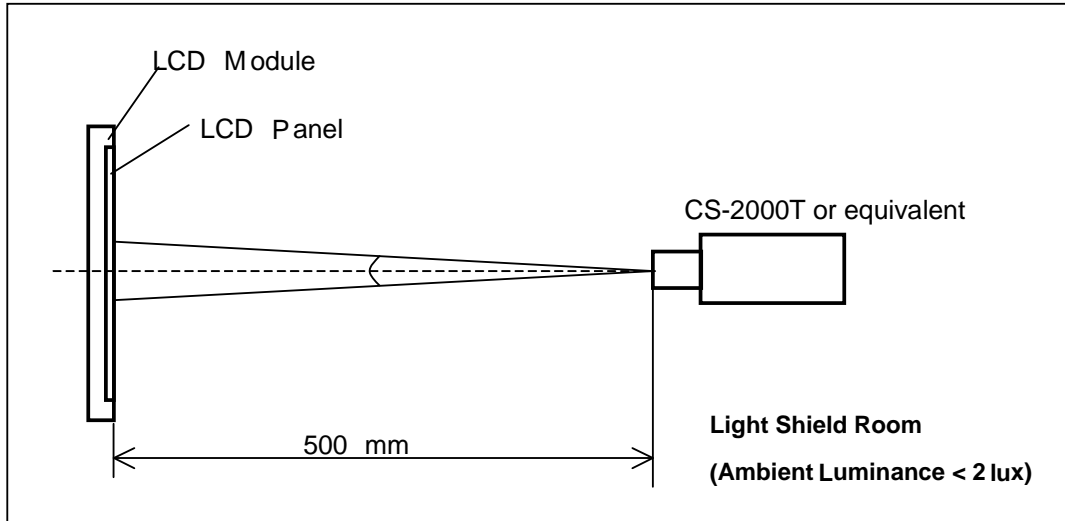

Note (5) Definition of Luminance of White (L_C , L_{AVE}):

Measure the luminance of gray level 255 at center point and 5 points

$L_C = L(5)$, where $L(X)$ is corresponding to the luminance of the point X at the figure in Note (7).

Note (6) Definition of Cross Talk (CT):

$$CT = |Y_B - Y_A| / Y_A \times 100 (\%)$$

Where:

Y_A = Luminance of measured location without gray level 0 pattern (cd/m²)

Y_B = Luminance of measured location with gray level 0 pattern (cd/m²)

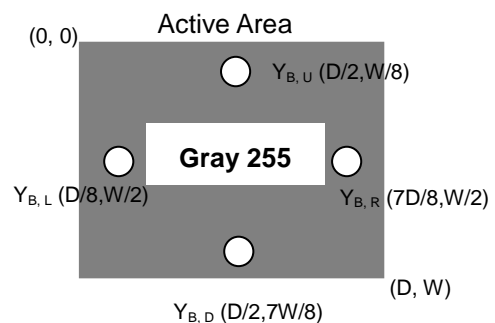
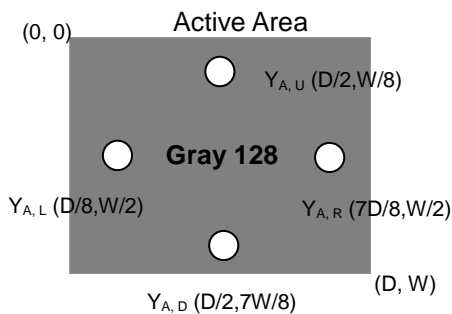

Note (7) Definition of White Variation (δW):

Measure the luminance of gray level 255 at 5 points

$$\delta W = \frac{\text{Maximum } [L(1), L(2), L(3), L(4), L(5)]}{\text{Minimum } [L(1), L(2), L(3), L(4), L(5)]}$$

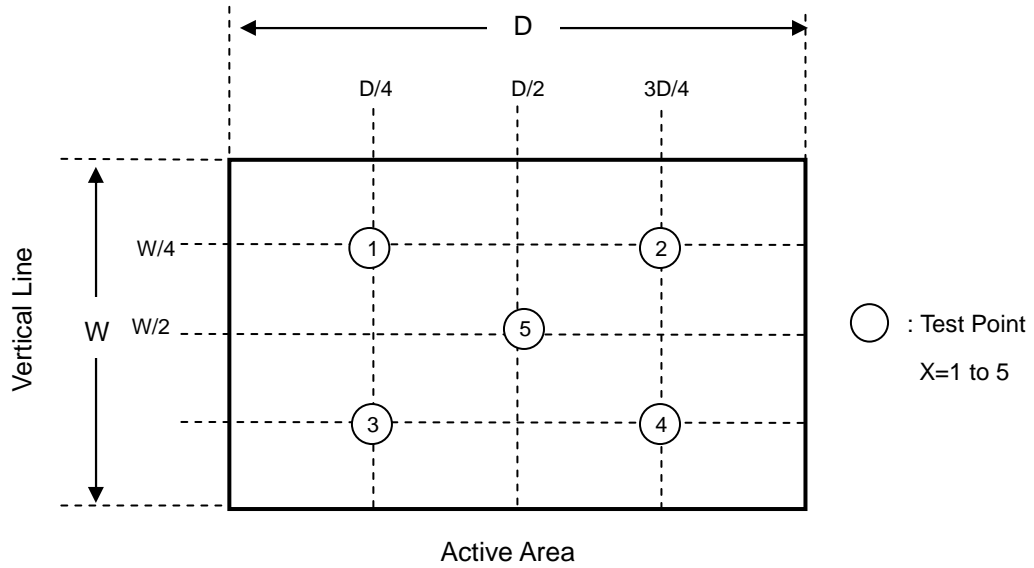

8. PRECAUTIONS

8.1 ASSEMBLY AND HANDLING PRECAUTIONS

- [1] Do not apply rough force such as bending or twisting to the module during assembly.
- [2] It is recommended to assemble or to install a module into the user's system in clean working areas. The dust and oil may cause electrical short or worsen the polarizer.
- [3] Do not apply pressure or impulse to the module to prevent the damage of LCD panel and Backlight.
- [4] Always follow the correct power-on sequence when the LCD module is turned on. This can prevent the damage and latch-up of the CMIS LSI chips.
- [5] Bezel of Set can not press or touch the panel surface. It will make light leakage or scrape.
- [6] Do not plug in or pull out the I/F connector while the module is in operation.
- [7] Do not disassemble the module.
- [8] Use a soft dry cloth without chemicals for cleaning, because the surface of polarizer is very soft and easily scratched.
- [9] Moisture can easily penetrate into LCD module and may cause the damage during operation.
- [10] When storing modules as spares for a long time, the following precaution is necessary.
 - [10.1] Do not leave the module in high temperature, and high humidity for a long time. It is highly recommended to store the module with temperature from 0 to 35°C at normal humidity without condensation.
 - [10.2] The module shall be stored in dark place. Do not store the TFT-LCD module in direct sunlight or fluorescent light.

8.2 SAFETY PRECAUTIONS

- [1] If the liquid crystal material leaks from the panel, it should be kept away from the eyes or mouth. In case of contact with hands, skin or clothes, it has to be washed away thoroughly with soap.
- [2] After the module's end of life, it is not harmful in case of normal operation and storage.

9. DEFINITION OF LABELS

9.1 INX MODULE LABEL

The barcode nameplate is pasted on each module as illustration, and its definitions are as following explanation.

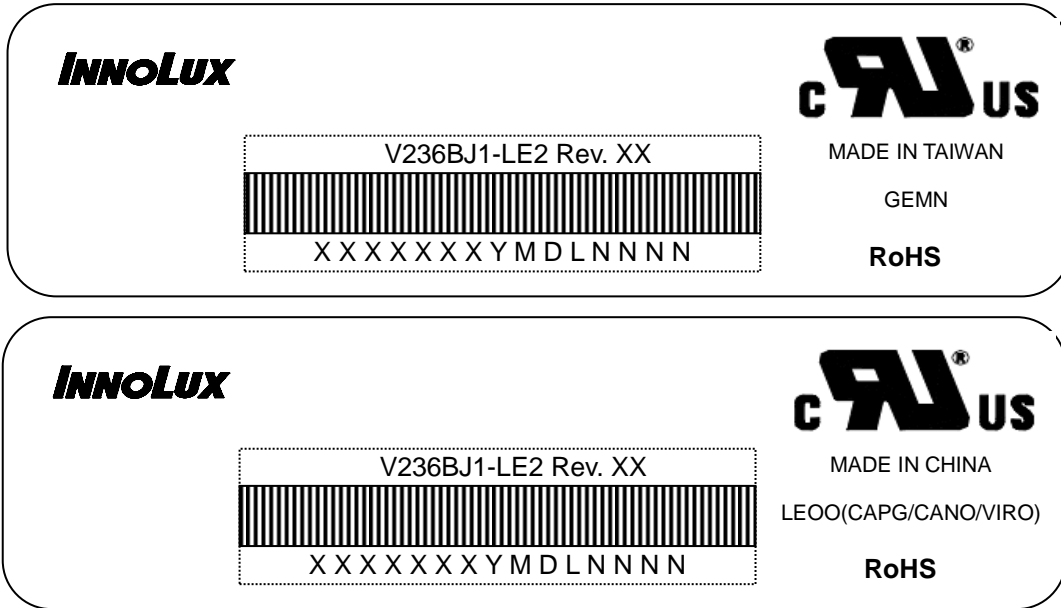

Model Name: V236BJ1-LE2

Revision: Rev. XX, for example: A0, A1... B1, B2... or C1, C2...etc.

Serial ID: X X X X X X Y M D L N N N N

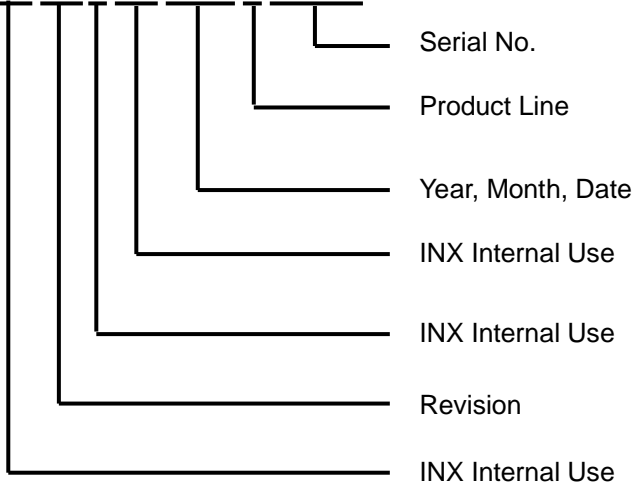

Serial ID includes the information as below:

Manufactured Date:

Year : 2001=1, 2002=2, 2003=3, 2004=4...2010=0, 2011=1, 2012=2...

Month: 1~9, A~C, for Jan. ~ Dec.

Day: 1~9, A~Y, for 1st to 31st, exclude I ,O, and U.

Revision Code : Cover all the change

Serial No. : Manufacturing sequence of product

Product Line : 1 → Line1, 2 → Line 2, ...etc.

10. PACKAGING

10.1 PACKING SPECIFICATIONS

- (1) 11 LCD modules / 1 Box
- (2) Box dimensions: 620(L) X 348(W) X 430(H) mm
- (3) Weight: approximately: 29.1kg (11 modules per box)

10.2 PACKAGING METHOD

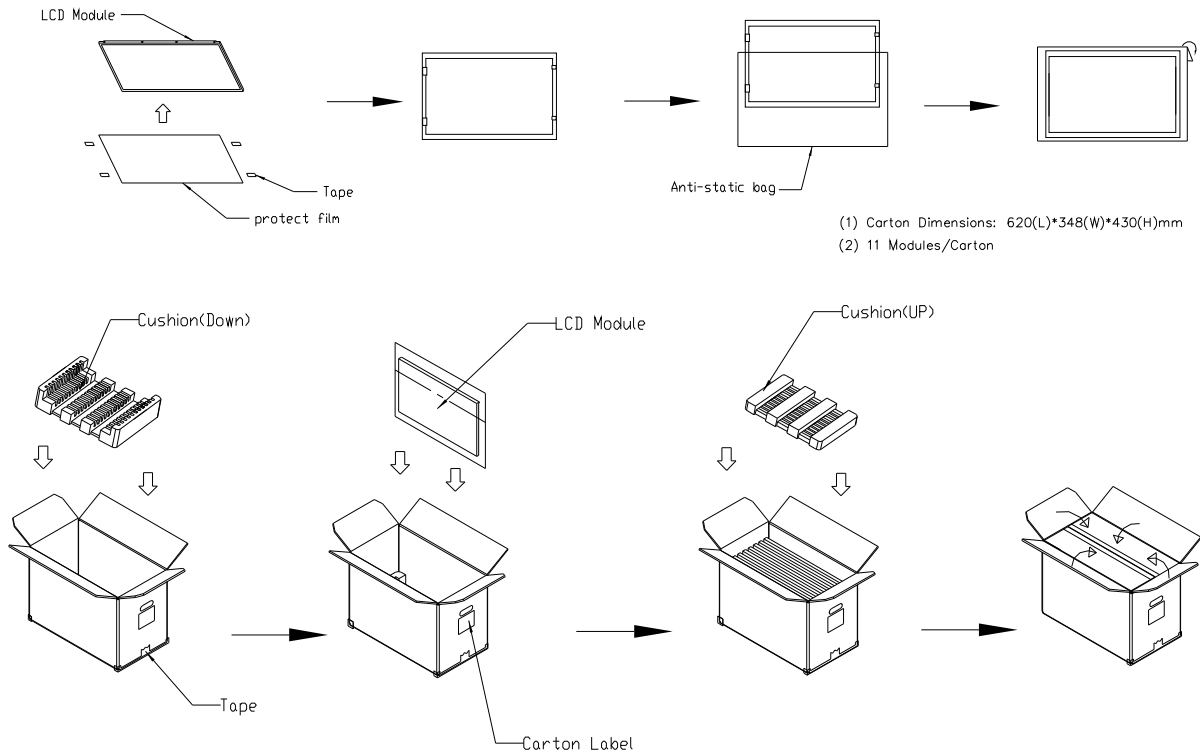
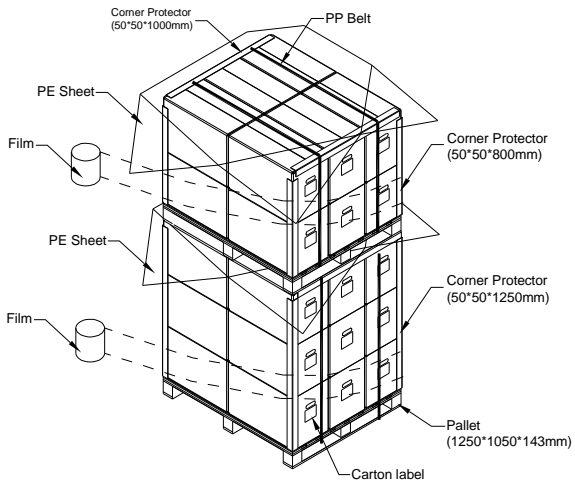

Figure 10-1 packing method

For ocean shipping

Sea / Land Transportation (40ft HQ Container)



Sea / Land Transportation (40ft/20ft Container)

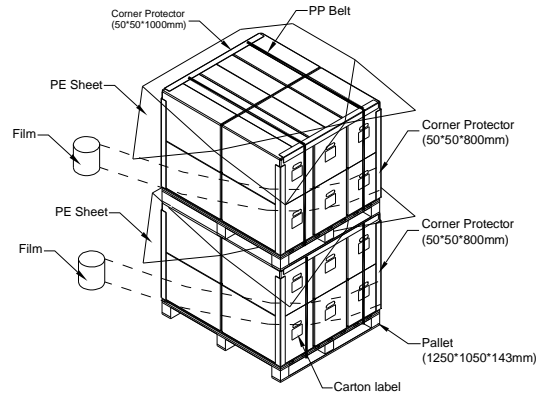

For air

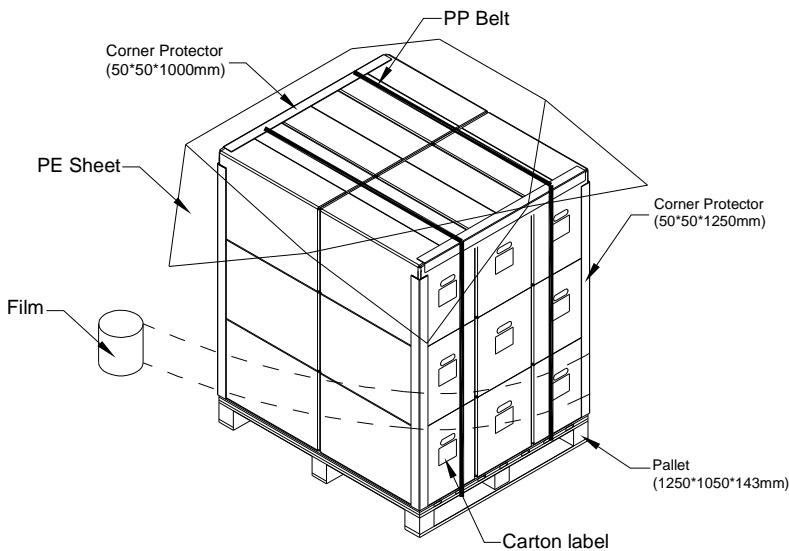

Figure 10-2 packing method

10.3 UN-PACKAGING METHOD

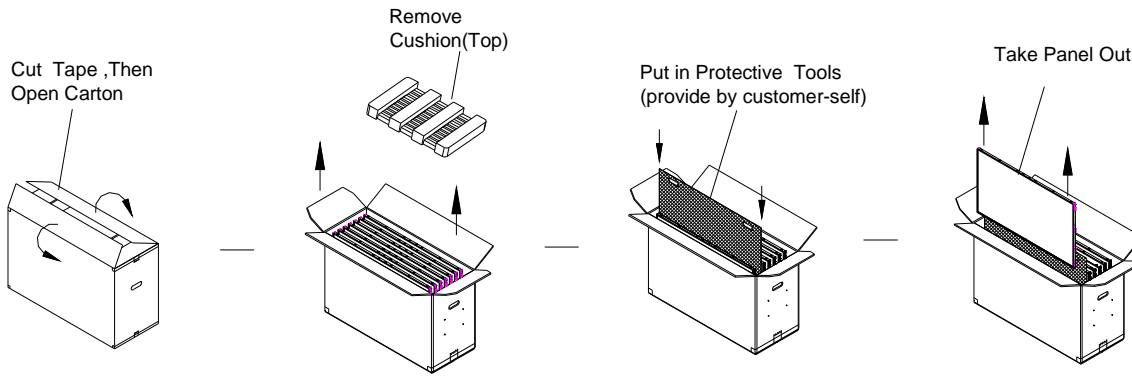

Figure 10-3 UN-packing method

